

	PART NO	CLEARANCE HOLE FOR SCREW	HOLE DIA
(B)	MTM1H-C	#8 (4mm)	.176 (4.47mm)
	MTM1H10-C	#10 (5mm)	.214 (5.43mm)
(A)	MTM1H25-C	#14 (6mm)	.281 (7.14mm)

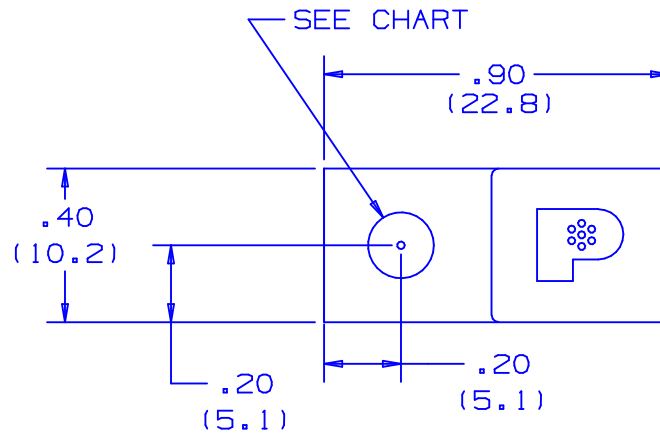

NOTES:

1. DIMENSIONAL TOLERANCES:
 .XX ±.02 (.50)
 .XXX ±.010 (.254)
2. USE WITH STD, LIGHT HEAVY, HEAVY MLT'S & 3/8" STRAPPING.
3. DIM'S IN () ARE mm.
4. PACKAGE C = 100

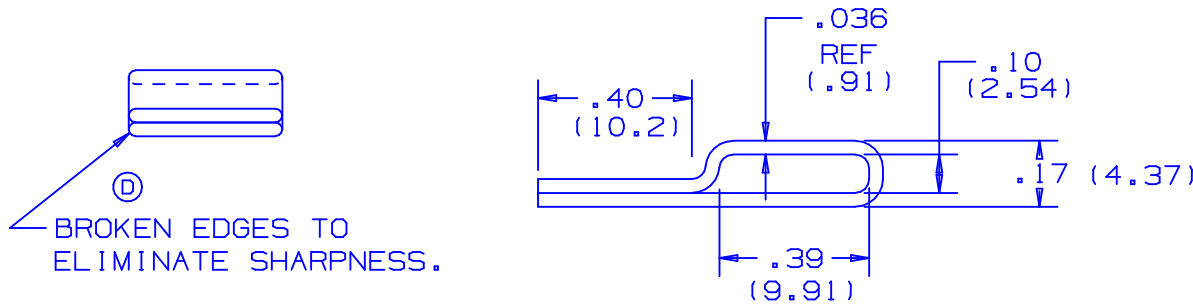

S41042_06

06	9/04	JAMB		(C) ADDED "LIGHT-HEAVY" MLT'S TO NOTE 2. (D) CHANGED "AISI NO.5 EDGE ROLLED TO" TO "BROKEN EDGES TO"	12052			PANDUIT CORP. TINLEY PARK, ILLINOIS METAL TIE MOUNT (1 HOLE)			
05	6/04	JAMB	DPN	(B) CHANGED PART NO. MTM1H8-C TO MTM1H-C	11723	CCH	JJB				
04	5/04	JAMB	DPN	(A) PART NO. CHANGED FROM MTM1H14C TO MTM1H25C	11714	CCH	JJB				
03	5/02	JAMB	DPN	MATERIAL WAS 302 S.S.	10042	CCH	JJB				
02	1/01	KMD	JAC	ADDED NOTE 4 CAD FILE SPEC WAS NPC-S41042-01	09010	CCH	JAC	UNLESS OTHERWISE SPECIFIED, DIMENSIONAL TOLERANCES ARE: (.X) ± (.XXX) ± (.XX) ± ANGLES ±			
01	5/92	DL	LM	ADDED MTM1H10 & MTM1H14	01012	GP	LM		UNLESS OTHERWISE SPECIFIED, ALL DIMENSIONS ARE GIVEN IN INCHES, THIRD ANGLE PROJECTION.		
--	----	--	--	MTM1H8 WAS MTM1H	----	--	--	DRAWN BY SAM	MAT'L: 304 STAINLESS STEEL	SCALE 2x	
00	3/91	SM	JC	RELEASED	00378	GP	LA	DATE 3/25/91		DRAWING NO. S41042	DWG A SIZE
REV	DATE	BY	CHK	DESCRIPTION	ECN #	PM	CUST	CHK'D LM			